

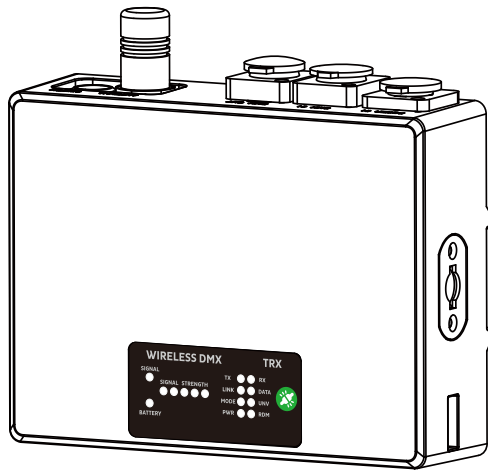

T1ULIP

Wireless DMX TRX



USER MANUAL

Safety information

1. Please read these instructions and safety instructions carefully before using this product.
2. Keep these instructions for future reference.
3. Never plug the product into the mains supply while it is still in its packaging. Never cover during use.
4. Only use indoors and in dry spaces, except where otherwise explicitly stated.
5. Verify that the product has not been damaged in transport before you make use of it.
6. Keep the product out of the reach of animals, children and persons who require supervision.
7. This product is intended for professional use only.
8. Always place the product on a stable, solid and flat base or safely secure it.
9. Do not use the product near hot surfaces or objects.
10. The mains cable must be regularly and carefully checked for damage to the cable, the plug and other parts. In the event of damage, the product must not be used until the mains cable has been replaced. If the product needs to be cleaned, the adapter or mains cable must be disconnected from the mains supply.
11. Repairs must only be carried out by a qualified person.
12. Note that the connected voltage and current corresponding to the sticker on the product.
13. Never submerge the product or the mains cable in water or any other liquid, in order to prevent electric shocks, fire, injury and other hazards.
14. Never carry the product by the cables and do not put the cord around sharp edges.

Mechanical Specification

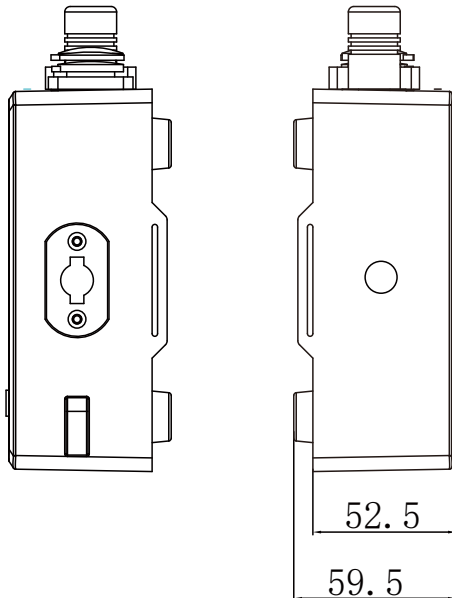
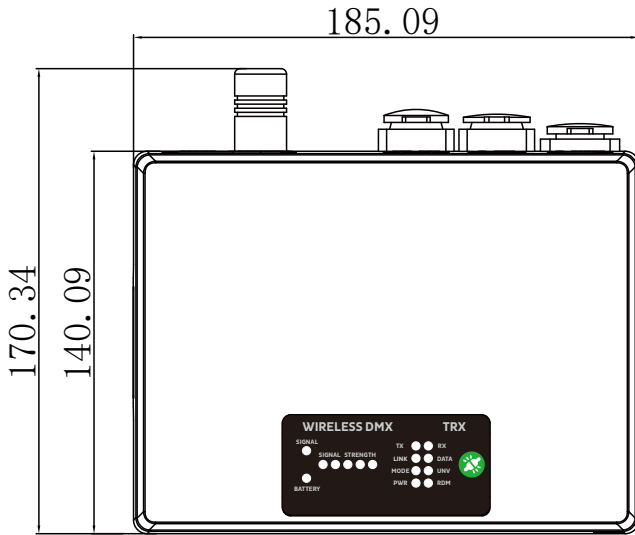

Technical specifications

- Input protocols: DMX 512 and RDM ANSI E1.20 (2)
- DMX Structure: 1 universes per device
- Number of DMX channels: 512 channels
- DMX latency: < 5 ms
- Max.Universes in coexistence: 32
- Input/Output opto isolation
- Error correction (Invisi-Wire)
- W-DMX G3 & G4S compatibility: 2.4 GHz,5.2 & 5.8 GHz (1)
- Standard range: Up to 700 meters (line of sight)
- Normal Power Mode 2.4 GHz: 100mW
- Maximum Power Mode 2.4 GHz: Up to 450mW
- DMX Connectors: 3 pin input and output
- AC Input: AC connector 3-pole: 100 - 250VAC & 50/60 Hz
(0.35A @ 115VAC - 0.2A @ 240VAC)
- DC Input: 2-pole DC 12V 2A power supply
- Supplied Accessories: 3dBi, white, omi-directional antenna and phoenix connector
- Charge time: 2.5H
- Discharge time: 88H @TX,440H@RX
- Net Weight: 1.8KG
- Gross Weight: 2.5KG
- Packed Dimensions: W x D x H: 185 x 59.5 x 170 mm
- Mounting: omega with fast lock,M10 holes for C clamp, with two holding points mount on the wall
- Temperature Range: -20 °C-45°C
- IP Rating: IP66

User Interface

Though the interface display appears simple, there is a lot of information you can read back, which will help you properly set up your system and help you understand how your devices are operating.

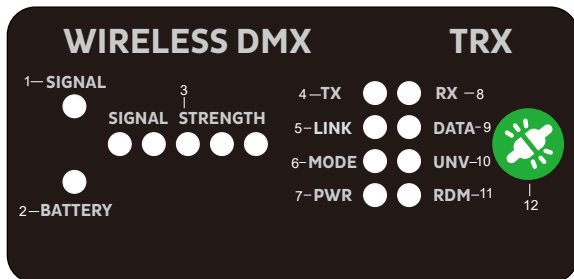

- 1. SIGNAL** Indicates that the Signal status is showing signal strength.
- 2. BATTERY**
 - Green: Fully charged
 - Red: Charging
- 3. SIGNAL STRENGTH** On a receiver; indicates the received signal quality. On a transmitter; indicates the configured output power.
- 4. TX** Device is operating as a transmitter.
- 5. LINK** On a transmitter; states it's ready to establish a link.
On a receiver;
 - Off: not linked to any transmitter
 - On: active link from a transmitter
 - Blinking: Linked to a transmitter but link is lost [either the transmitter is outof-range or turned off].
- 6. MODE** Indicates the radio mode.
- 7. PWR** States power condition of the device.
- 8. RX** Device is operating as a receiver.
- 9. DATA**
 - Off: No data
 - Green: DMX data
 - Red: RDM activity
- 10. UNV**
- 11. RDM** Flashes when there is RDM traffic activity.
- 12. Function button**

Product Overview

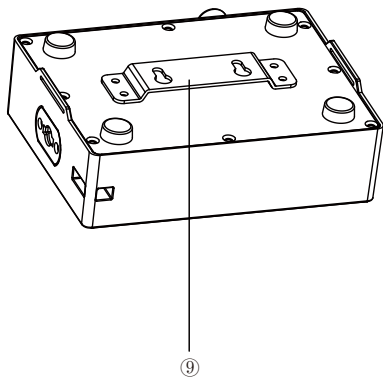
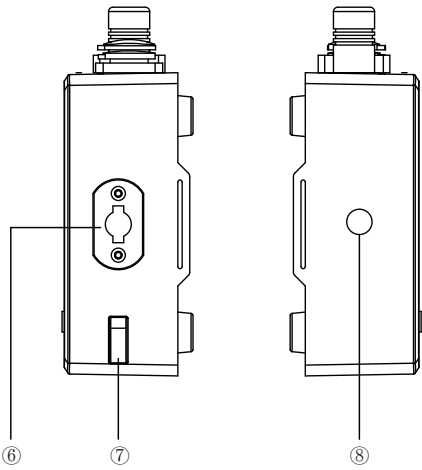
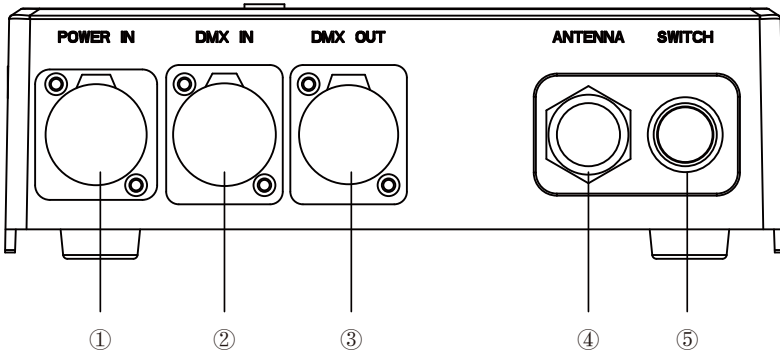

- 1. POWER IN
- 2. DMX IN
- 3. DMX OUT
- 4. ANTENNA
- 5. SWITCH

- 6. Fast lock
- 7. Holes for safety wire
- 8. M10 and 3/8" holes
- 9. Holes for Wall Mounting

Wireless DMX in a nutshell

Wireless DMX can be used in many different setups, may it be one single universe being transmitted from one point over a distance to one receiver. This is what is called point-to-point, and is a common scenario when shooting wireless DMX over a distance where cable is not possible. The cable is simply replaced with a wireless cable with a fixed latency of 5 ms.

Point-to-point operation:

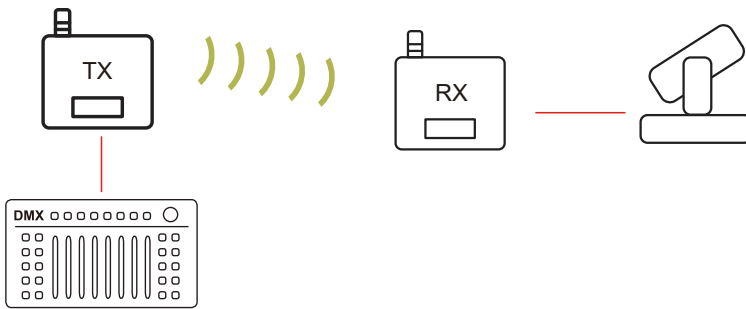

Point-to-multipoint operation:

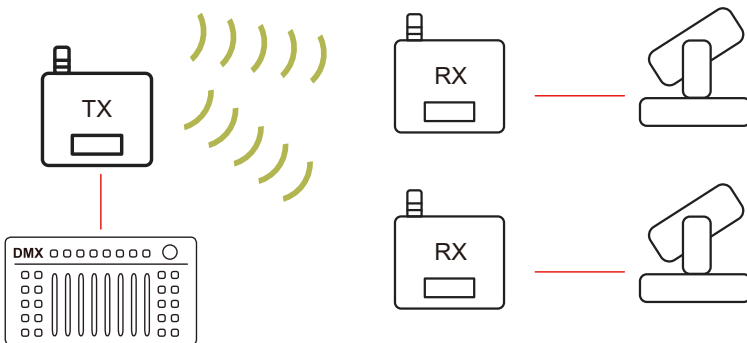

Multipoint-to-multipoint operation:

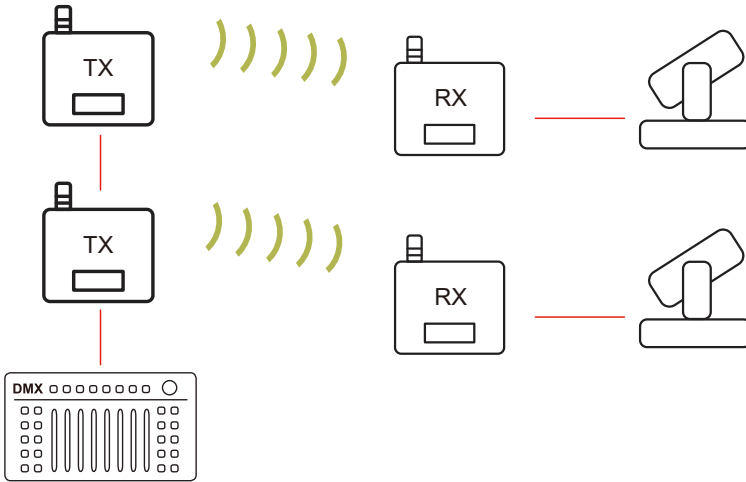

Operation

1. Basic setup – Linking devices

A basic setup is defined by the link between two devices. This means that, in order to send data from a transmitter to a receiver, it's necessary to link the devices:

Press the green function button, on the transmitter momentarily and the LINK LED starts flashing.

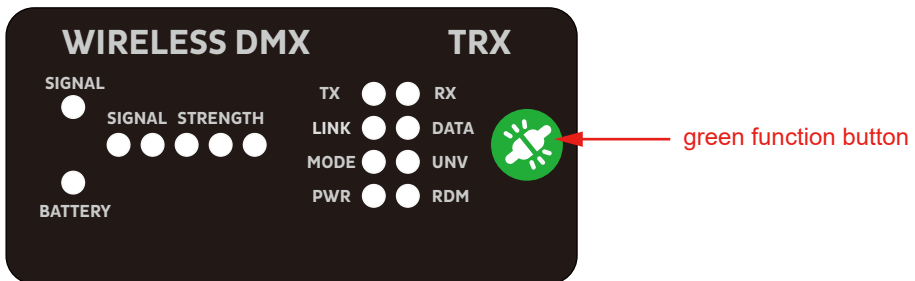

NOTE: All available (currently unlinked) receivers, as long as they are turned on and compatible with the transmitter's radio mode, will pair with this transmitter. The LINK LED of each receiver will flash for 5 seconds, and then stay static once linked up.

There is no limit of the number of receivers that can link up with a transmitter – there can be an infinite number of receivers all paired with a single transmitter.

2. Unlinking devices

There are two ways to unlink devices – individual unlink, or group unlink:

Individual unlink:

Press and hold the green function button, on each receiver that you wish to unlink, for at least 3 seconds. The LINK LED will turn off.

Group unlink:

Press and hold the green function button on the transmitter for at least 3 seconds. This will unlink all currently powered receivers that are linked to this transmitter.

3. Linking multiple transmitters with multiple receivers

When multiple receivers need to be linked up with different transmitters, repeat the process in 6.1., but turn off all receivers you do not wish to pair up. For example:

- If you have 2 transmitters and 10 receivers, pair the first transmitter to 5 receivers, while the last five are turned off.
- After that, turn the last five receivers, and pair them to the second transmitter.

NOTE: This will not affect any receiver that has already been paired up.

4. Switching FLEX mode

All units identified as a transceiver can be changed between transmitter or receiver – the units capable to operate in both modes are listed in chapter 2.

FLEX mode determines if the unit is used in transmit mode (TX) or receive mode (RX):

1. Press the red function button rapidly 5 times.
2. Press and hold the red function button for at least 3 seconds.
3. The LINK and DATA LEDs will flash alternating.
4. Each time you press the red function button you will step through the available modes, this will be indicated by a flashing RX or TX LED.
5. Press and hold the red function button.

Compatibility

There has been two major wireless DMX systems on the market for a while - CRMX® and W-DMXTM.

They have historically not been fully compatible due to different technologies being used. But CRMX receivers have been able to receive the W-DMX G3 protocol. However, your new CRMX Aurora or CRMX Luna can be operated in different modes when in transmitter mode;

1. **CRMX** - transmit CRMX data to compatible receivers.
2. **W-DMX G3** - transmit W-DMX G3 protocol.
3. **W-DMX G4S** - transmit W-DMX G4S protocol.

For W-DMX receivers, please use the W-DMX G3 mode for maximum compatibility.

Note: This mode can also be used with CRMX receivers, but security and DMX fidelity is not as good as when running CRMX mode.

Mode	CRMX receivers	Older CRMX receivers	W-DMX receivers
CRMX	Yes	Yes	No
W-DMX G3	Yes	Yes	Yes
W-DMX G4S	Yes	No	Yes

When operated as receivers, CRMX Aurora and CRMX Luna will automatically detect and link using the protocol used by the transmitter at the time of linking.

Linking key

What is Linking Key

The Linking Key is a user-defined 8 digit key code. It can be used as a password to to the link credentials of a CRMX link. It can be used to tell two (or more) different transmitters to set up identical links. This is what we call cloned transmitters.

It can also be used to link a receiver to a transmitter that has an active link using the same linking key. This allows for easy addition of a receiver to a network where the transmitter might be inaccessible for instance, without the need to initiate a linking process from the transmitter.

Cloning transmitters

By cloning transmitters, by entering the same Linking Key into both transmitters, you can place them at separate physical locations and move receives between the locations without the need to relink.

Note: It is important that the transmitters are separated, otherwise receivers may end up creating a link with any of the transmitters, which may lead to undefined behaviour.

Linking an RX by Linking Key

In receivers that supports it, it is possible to enter the linking key of the transmitter to join that network without the need for performing a linking procedure from the transmitter.

Enter the same Linking Key into the receiver as you have entered into the transmitter and the receiver will automatically link to the transmitter when it is within range.

Tips & tricks

There are limitations to how wireless waves propagate through air. Physical barriers like glass, concrete and walls will limit the transmission range. Always try to have clear line-of-sight between transmitters and receivers.

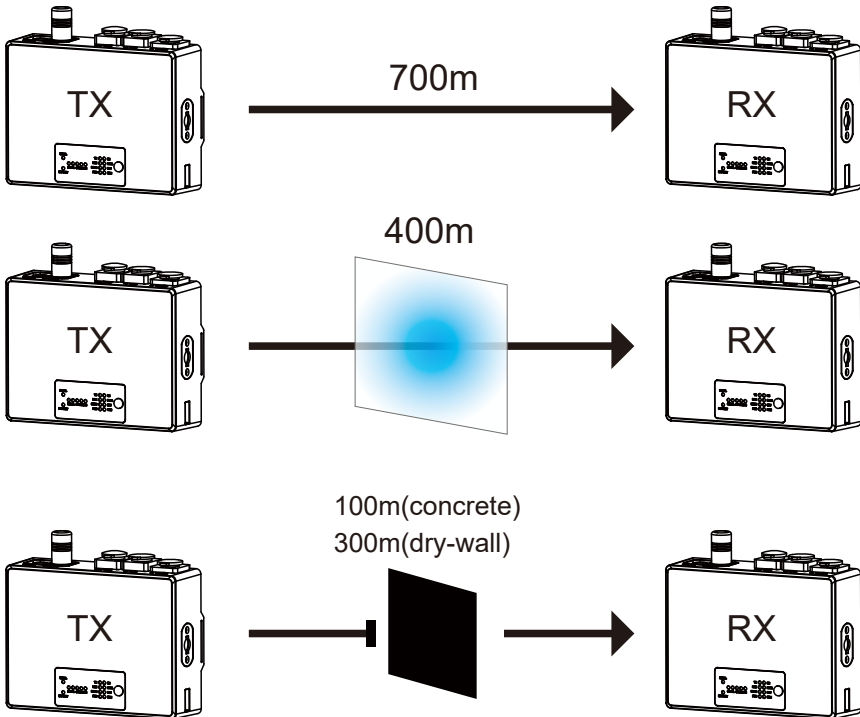

Mounting

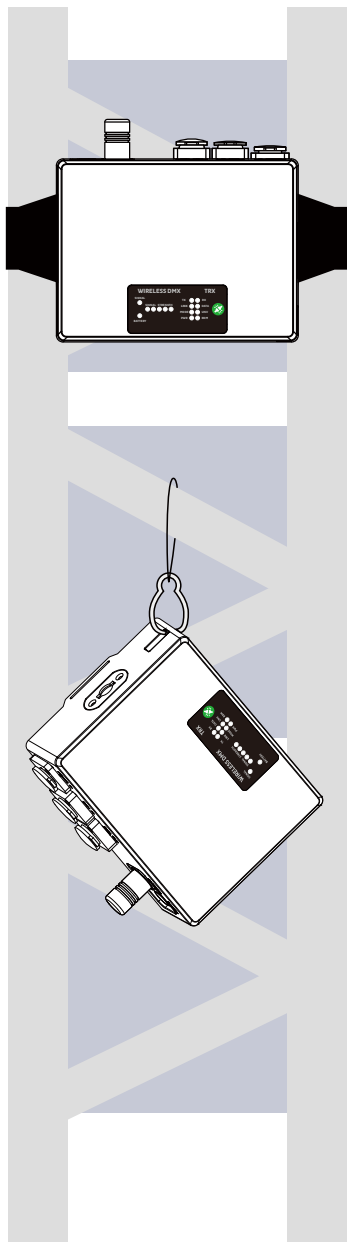

01. Velcro

Wireless DMX TRX fastened on truss by velcro

02. Safety wire

There are holes on the device where a safety wire shall be fastened.

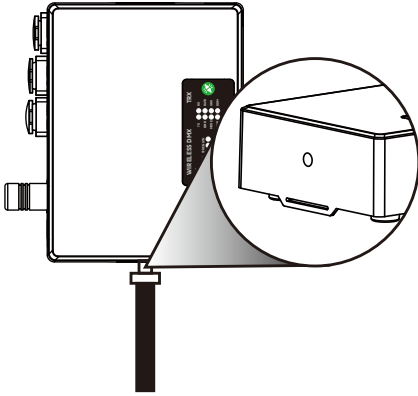

03. M10 and 3/8" holes

On either side of your Wireless DMX TRX unit you'll find holes for M10 (1.5 mm pitch) and 3/8" (UNC). These can be used with any standard truss mounting clamps or spigots, for instance a standard TV spigot. Do not use screws that can go deeper than 27 mm.

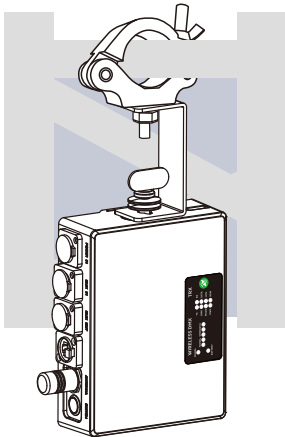

04. Omega with fast lock

Wireless DMX TRX fastened on truss by omega with fast lock.

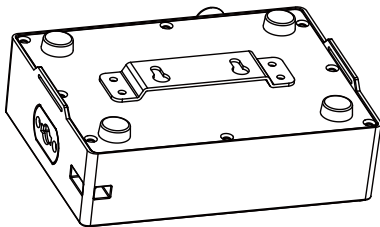

05. Wall mounting

Wireless DMX TRX can be mounted to a wall using the wall mounting kit (sold separately). Loosen the lower two M4 screws on each side of the unit, place the brackets and fasten them using the M4 screws. Tighten firmly.

Safety information



- This device is suitable for indoor use only.
- All modifications to the device will void the warranty.
- Repairs are to carry out by skilled personnel only.
- Use only fuses of the same type and original parts as spare parts.
- Protect the unit from rain and humidity to avoid fire and electric shocks.
- Make sure to unplug the power supply before opening the housing.

FOR SAFE AND EFFICIENT OPERATION

Be careful with heat and extreme temperature

Avoid exposing it to direct rays of the sun or near a heating appliance.

Not put it in a temperature bellow 32°F /0°C, or exceeding 131°F /55°C.

Keep away from humidity, water and dust

Do not place the set in a location with high humidity or lots of dust.

Containers with water should not be placed on the set.

Keep away from sources of hum and noise

Such as transformer motor, tuner, TV set and amplifier.

To avoid placing on un-stable location

Select a level and stable location to avoid vibration.

Do not use chemicals or volatile liquids for cleaning

Use a clean dry cloth to wipe off the dust, or a wet soft cloth for stubborn dirt.

If out of work, contact sales agency immediately

Any troubles arose, remove the power plug soon, and contact with an engineer for repairing,

do not open the cabinet by yourself, it might result a danger of electric shock.

Take care with the power cable

Never pull the power cable to remove the plug from the receptacle, be sure to hold the plug. When not using the device for an extended period of time, be sure to disconnect the plug from the receptacle.

Important: Damages caused by the disregard of this user manual are not subject to warranty. The dealer will not accept liability for any resulting defects or problems. Make sure the electrical connection is carried out by qualified personnel. All electrical and mechanical connections have to be carried out according to the European safety standards.

